

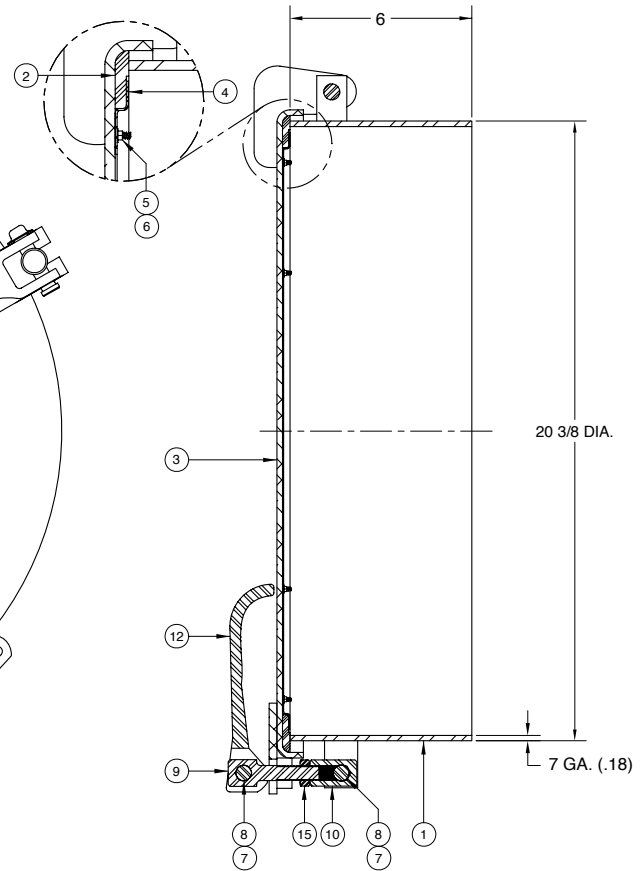

AN **OPW** FLUID TRANSFER GROUP COMPANY

# KP1110 20" Manhole Assembly

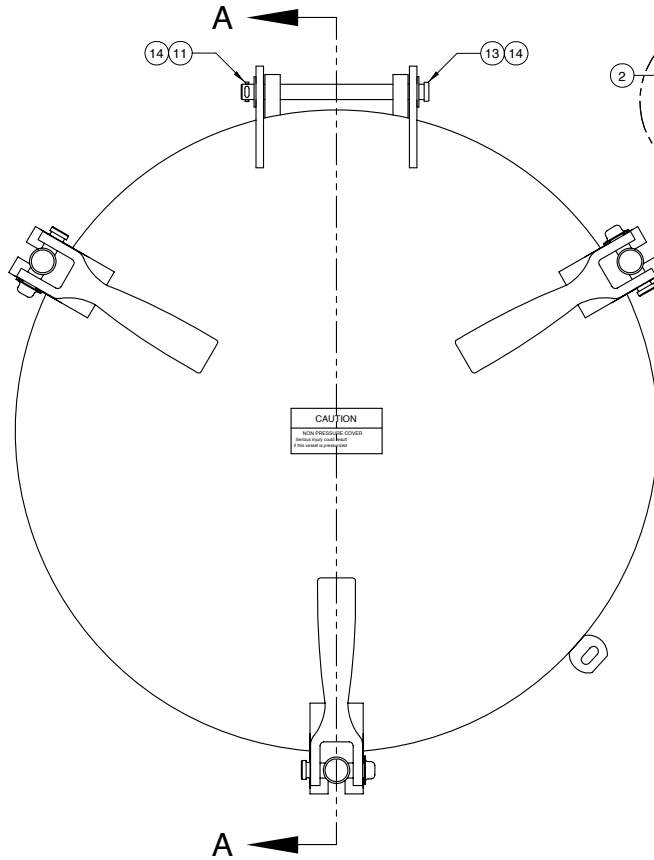

SECTION A-A

ITEM	PART NUMBER	DESCRIPTION	QTY.
1	1457	WELD RING ASSY (STEEL)	1
2	1026	GASKET (BUNA)	1
3	1456	COVER WELDMENT (STEEL)	1
4	1027	GASKET RETAINER (STEEL)	1
5	1059	HEX NUT (PLATED)	6
6	1036	WASHER (PLATED)	6
7	1020	PAL NUT (PLATED) <sup>1</sup>	6
8	3952	CLEVIS PIN (PLATED) <sup>1</sup>	6
9	1011	STUD (PLATED) <sup>1</sup>	3
10	1012	CONNECTOR (PLATED) <sup>1</sup>	3
11	1045	COTTER PIN (PLATED)	1
12	1013	CAM LEVER (STEEL) <sup>1</sup>	4
13	1042	CLEVIS PIN (PLATED)	1

ITEM	PART NUMBER	DESCRIPTION	QTY.
14	1043	WASHER (PLATED)	2
15	1016	JAM NUT (PLATED) <sup>1</sup>	3

### ALTERNATE SEALING MEDIA / CAM ASSEMBLIES

PART NUMBER	DESCRIPTION
1432	GASKET (WHITE NEOPRENE)
1674	GASKET (EPDM)
5012	GASKET (SILICONE)
2726	GASKET (HI-TEMP.)
2573	GASKET (VITON)
1836	CAM ASSEMBLY KIT (STEEL)
1837	CAM ASSEMBLY KIT (PLATED)

1 - Included in 1836



PHONE: (816) 741-6600 • (888) 526-5657 • Fax: (816) 741-1061  
 4304 Mattox Road • Kansas City, MO 64150 • [www.knapppco.com](http://www.knapppco.com)