

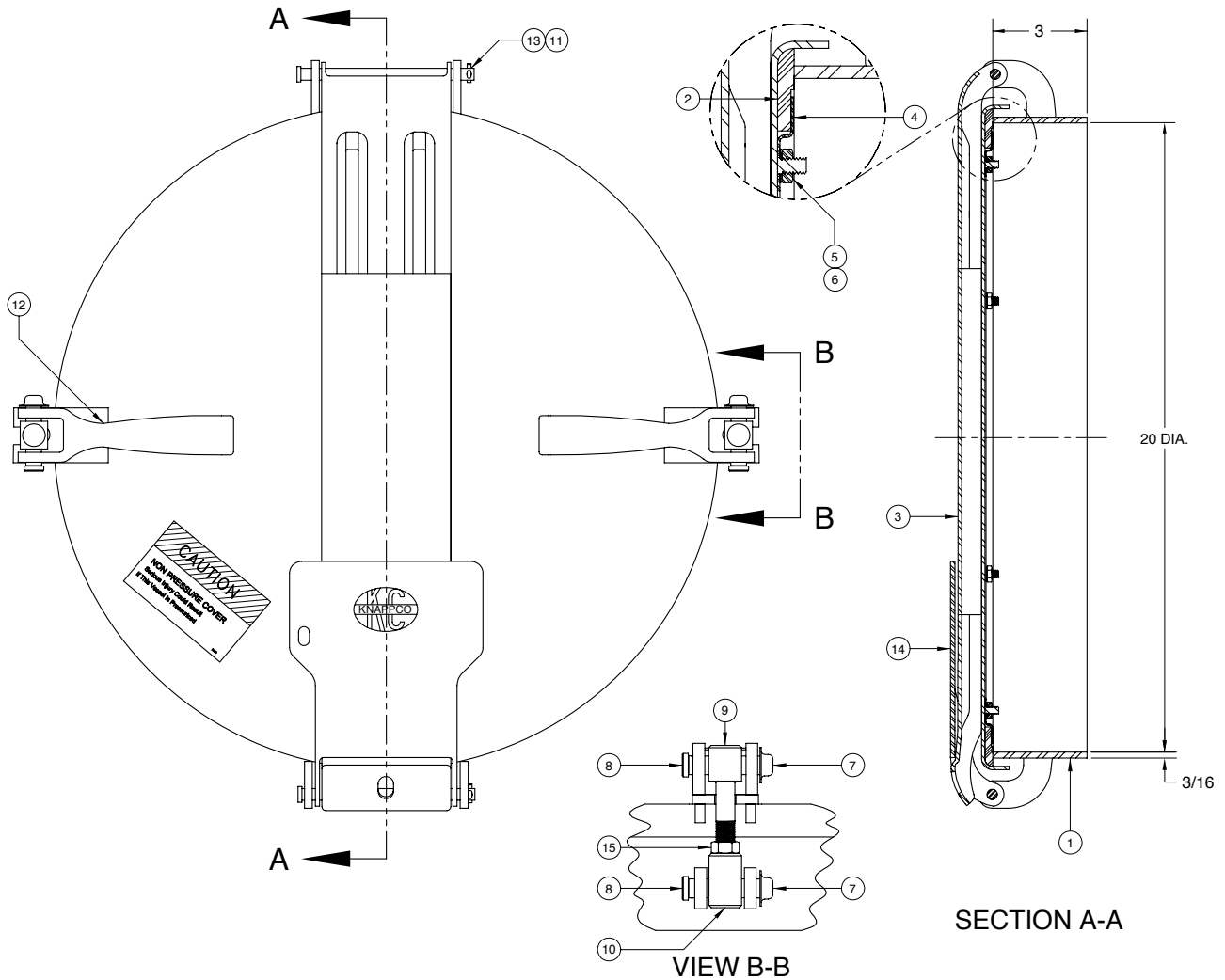

AN **OPW** FLUID TRANSFER GROUP COMPANY

KM1110 20" Manhole Assembly



ITEM	PART NUMBER	DESCRIPTION	QTY.
1	1349	WELD RING ASSY (STEEL)	1
2	1026	GASKET (BUNA)	1
3	1346	COVER WELDMENT (STEEL)	1
4	1027	GASKET RETAINER (STEEL)	1
5	1059	HEX NUT (PLATED)	6
6	1036	WASHER (PLATED)	6
7	1020	PAL NUT (PLATED) ¹	4
8	3952	CLEVIS PIN (PLATED) ¹	4
9	1011	STUD (PLATED) ¹	2
10	1012	CONNECTOR (PLATED) ¹	2
11	1045	COTTER PIN (PLATED)	2
12	1013	CAM LEVER (STEEL) ¹	2

ITEM	PART NUMBER	DESCRIPTION	QTY.
13	2106	CLEVIS PIN (PLATED)	2
14	1125	LATCH (STEEL)	1
15	1016	JAM NUT (PLATED)	2

ALTERNATE SEALING MEDIA

PART NUMBER	DESCRIPTION
1432	GASKET (WHITE NEOPRENE)
2573	GASKET (VITON)
2726	GASKET (HIGH TEMP.)
1836	CAM LEVER ASSY. (STEEL)
1837	CAM LEVER ASSEMBLY (PLATED)



PHONE: (816) 741-6600 • (888) 526-5657 • Fax: (816) 741-1061
 4304 Mattox Road • Kansas City, MO 64150 • www.knappco.com