

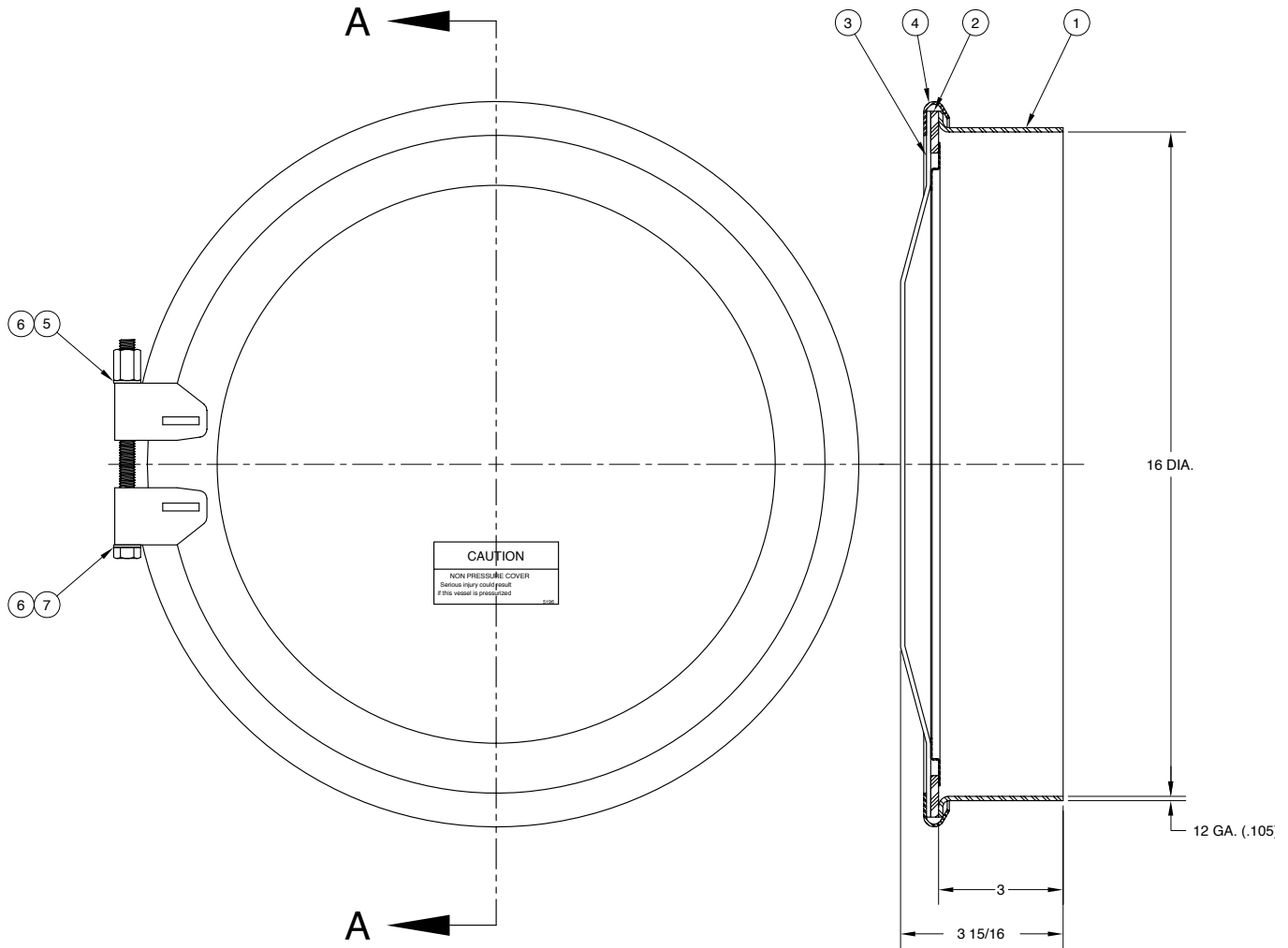

AN OPW® FLUID TRANSFER GROUP COMPANY

# KF1110 16" Manhole Assembly



## SECTION A-A

| ITEM | PART NUMBER | DESCRIPTION              | QTY. |
|------|-------------|--------------------------|------|
| 1    | 1089        | WELD RING (STEEL)        | 1    |
| 2    | 1106        | GASKET (BUNA)            | 1    |
| 3    | 1266        | COVER WELDMENT (STEEL)   | 1    |
| 4    | 1107        | CLAMP RING ASSY. (STEEL) | 1    |
| 5    | 5009        | HEX NUT (BRASS)          | 1    |
| 6    | 1113        | WASHER (PLATED)          | 2    |
| 7    | 1110        | HEX CAP SCREW (PLATED)   | 1    |

### ALTERNATE SEALING MEDIA

| PART NUMBER | DESCRIPTION              |
|-------------|--------------------------|
| 2558        | GASKET (WHITE NEOPRENE)  |
| 1377        | GASKET (HIGH TEMP.)      |
| 4686        | GASKET (SILICONE)        |
| 4821        | GASKET (TEFLON ENVELOPE) |
| 4612        | GASKET (EPDM)            |



PHONE: (816) 741-6600 • (888) 526-5657 • Fax: (816) 741-1061  
4304 Mattox Road • Kansas City, MO 64150 • [www.knappco.com](http://www.knappco.com)