

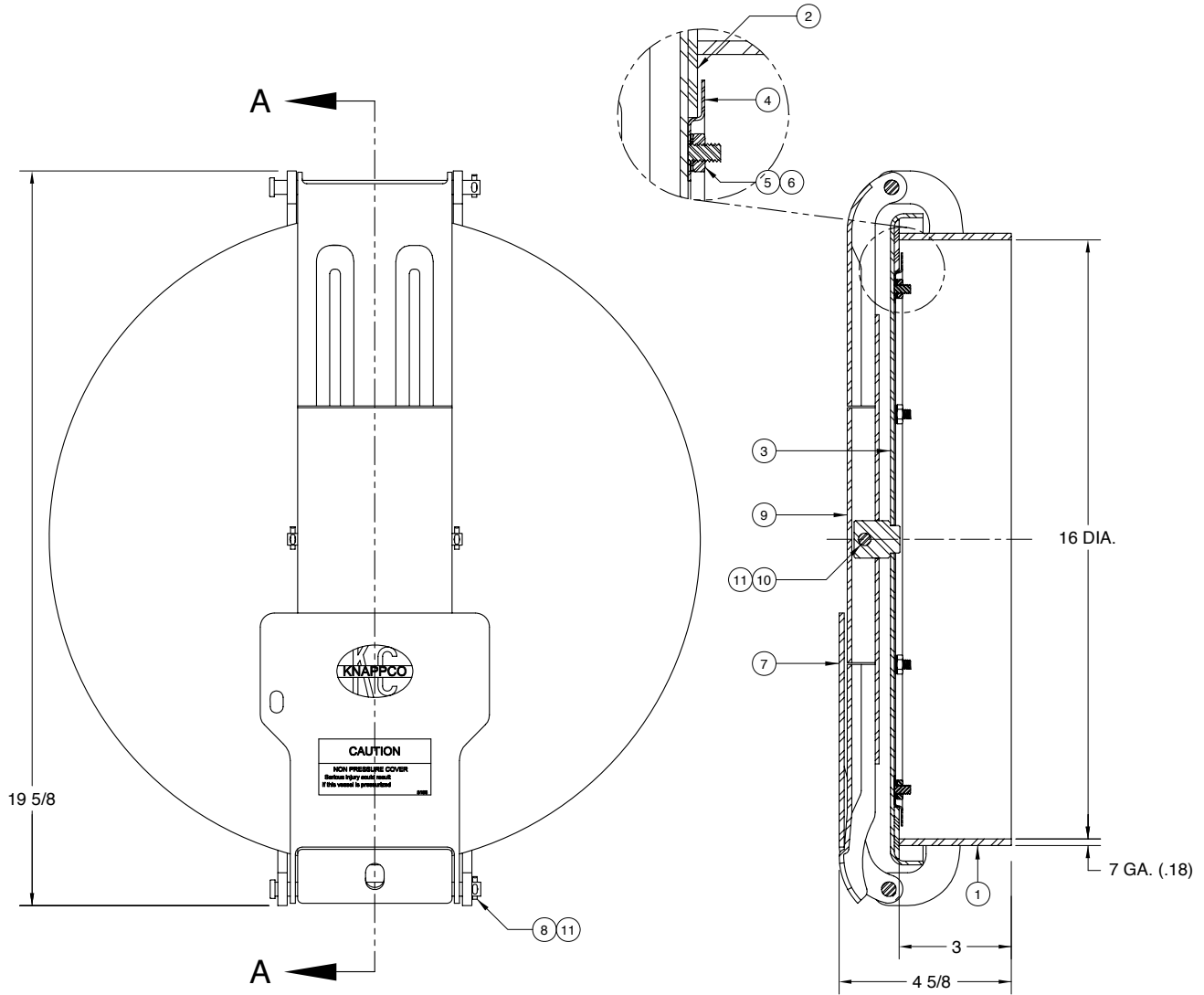

AN OPW® FLUID TRANSFER GROUP COMPANY

LD4410 16" Manhole Assembly



SECTION A-A

ITEM	PART NUMBER	DESCRIPTION	QTY.
1	3747	WELD RING ASSY (316 S.S.)	1
2	1294	GASKET (BUNA)	1
3	3748	COVER WELDMENT (316 S.S.)	1
4	5000	GASKET RETAINER (316 S.S.)	1
5	4053	HEX NUT (316 S.S.)	6
6	1330	WASHER (316 S.S.)	6
7	1127	LATCH (316 S.S.)	1
8	2090	CLEVIS PIN (316 S.S.)	2
9	3106	STRONGBACK ASSY. (316 S.S.)	1

ITEM	PART NUMBER	DESCRIPTION	QTY.
10	2920	PIN (316 S.S.)	1
11	1083	COTTER PIN (316 S.S.)	4

ALTERNATE SEALING MEDIA

PART NUMBER	DESCRIPTION
3145	GASKET (WHITE NEOPRENE)
2685	GASKET (HIGH TEMP.)
3889	GASKET (VITON)
2567 / 1294	GASKET (TEFLON ENVELOPE)



PHONE: (816) 741-6600 • (888) 526-5657 • Fax: (816) 741-1061
 4304 Mattox Road • Kansas City, MO 64150 • www.knappco.com